

SUPERball: Exploring Tensegrities for Planetary Probes

Jonathan Bruce^{*±}, Andrew P. Sabelhaus^{**‡}, Yangxin Chen^{**∩}, Dizhou Lu^{**∪},
Kyle Morse^{***◊}, Sophie Milam^{***⊕}, Ken Caluwaerts^{†^}, Alice M. Agogino^{**ℓ}, Vytas SunSpiral^{‡II}

*University of California, Santa Cruz, USA
±jbruce@soe.ucsc.edu

**University of California, Berkeley, USA
‡apsabelhaus@berkeley.edu
∩okingjo@berkeley.edu
∪ludizhou@berkeley.edu
ℓagogino@berkeley.edu

***University of Idaho, USA
◊mors9075@vandals.uidaho.edu
⊕mila0725@vandals.uidaho.edu

†Ghent University, Belgium
^ken.caluwaerts@ugent.be

‡SGT Inc., NASA Ames Research Center, USA
IIvytas.sunspiral@nasa.gov

Abstract

The Dynamic Tensegrity Robotics Lab (DTRL) at NASA Ames Research Center is developing a compliant and distributed tensegrity robotic platform for planetary exploration. Working in collaboration with Ghent University, the DTRL built an untethered prototype robot, the SUPERball. In this work, multiple issues with the current SUPERball design are addressed, when considering an example mission to Titan. Specifically, engineering requirements for the mission are empirically validated, and the current design is extended under these requirements to meet expanded goals. Survival of impact forces under entry, descent, and landing are verified with a physical experiment performed in collaboration with the University of Idaho. Then, concepts for a fully-actuated re-design of SUPERball are generated, compared, and validated against current engineering requirements. This exploratory work moves the SUPERball project toward an eventual flight-ready design.

1 Introduction

NASA is supporting research into tensegrity robotics for emerging space missions. Pure tensegrity systems, a portmanteau of “tensile-integrity,” contain rigid rods in a network of tension such that no two rigid elements are in contact. Their high strength-to-weight ratio and deployability from compact configurations, which enable them to fit into small constrained launch fairings, have inspired studies of deployable antennae and other large space structures [1]. For planetary exploration, the global force redistribution property of tensegrity structures is a property NASA is quite interested in researching [2]. Science has even emerged showing that tensegrity structures are found in a wide gambit of nature from cells to human anatomy [3][4]. A tensegrity mission can have a high

mass fraction between science payload and overall weight (as measured at atmospheric entry) due to its ability to perform EDL and mobility. This will enable cheaper and new forms of surface exploration that utilize their natural tolerance to impacts [5].

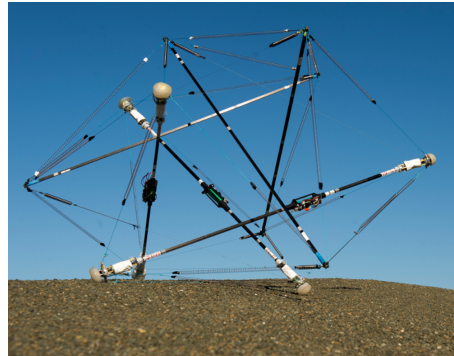

Figure 1. Ghent University’s ReCTeR tensegrity robot, the ideological predecessor to DTRL’s SUPERball, which maintains the same geometry.

SUPERball, the Spherical Underactuated Planetary Exploration Robot Ball, is a distributed robotic system design prototype in active development at the Dynamic Tensegrity Robotics Lab (DTRL) at NASA Ames Research Center [6]. This robot’s distributed communication, control, and structure stems from the decentralized nature inherent to tensegrities. Each rigid rod is a self-contained robotic system consisting of two smaller intelligent nodes, which the DTRL has termed “endcaps.” Such intelligent actuated elements are at the core of any distributed tensegrity robot, like SUPERball. Figure 2 shows a current hardware prototype of a SUPERball endcap that is currently being tested. The goal configuration for SUPERball is a 6-bar icosahedron, with 24 cables in its ten-

sion network much like its ideological predecessor, Ghent University's ReCTeR robot in Figure 1.

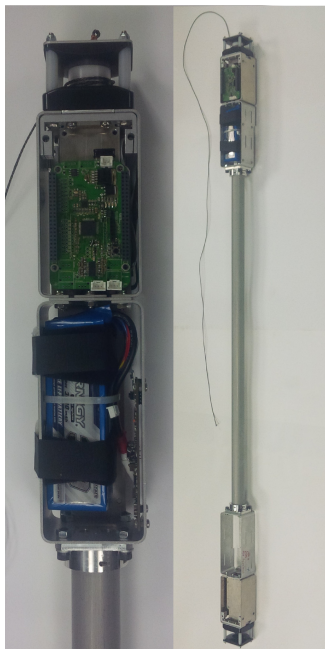

Figure 2. Current version of a prototype rod from NASA's tensegrity robot, SUPERball.

In order to execute a tensegrity-based space mission, there are numerous challenges that have yet to be addressed. Here, two of these outstanding issues are researched, and progress is made toward eventual solutions. This work discusses the current state of our work validating the dynamic landing force estimates from SunSpiral et al [5] as well as exploring actuation specifications based on Icsen et al's [7] control scheme. These controls, which are designed to pull on specific cables such that the robot rolls forward in dynamic locomotion, are the state of the art in mobile control of tensegrity robots. First, current and previous the specifications are discussed. This will be followed by a section on the current structural validation tests, and a section on concept designs to expand the actuation of SUPERball to meet the requirements for better versions of the current published control schemes.

These two areas of work are tied by the same crucial link of structural integrity for a future physical robot. The validation of forces on the structure in section 3 is envisioned to be used in more advanced development of engineering requirements, of which a preliminary set are used in the fully-actuated redesign in section 4. The ongoing work to estimate, predict, and analyze the impact of forces on the structure of an envisioned tensegrity planetary lander guide this research.

2 Motivation and Prior Work

Exploration of scientifically interesting planetary bodies, such as Saturn's moon Titan, will require rovers which are capable of traversing unmapped or low resolution mapped terrain and diverse terrain profiles, adapting to long communication delays, and efficiently shuttling long distances through our solar system. Tensegrity robotics show promise in efficiently addressing all these high-level requirements. NASA has funded this idea, embodied in the SUPERball, through an Innovative Advanced Concepts (NIAC) grant [2]. This NIAC project seeks to build a tensegrity robotic system that is capable of performing EDL (Entry, Descent, and Landing) tasks and then moving around on Titan's surface once it has landed. The outer structure performs both landing and locomotion functions, saving weight and cost. While the tensegrity structure will be for EDL and mobility, a payload with various science equipment will be suspended within the middle of the structure. Building a rover capable of executing diverse EDL scenarios gives the exploration mission more freedom to explore areas inaccessible or dangerous for current rover platforms, e.g. lava tubes.

2.1 Drop Test Work

The DTRL team has already explored a tensegrity EDL concept design validation through simulations and an initial drop test of a basic tensegrity robotic structure in [5]. It was shown that a tensegrity structure has the potential to handle various landing orientations during an EDL scenario on Titan while protecting the scientific payload from large deceleration forces due to impact dynamics. This result was achieved by utilizing two separate simulation environments: an Euler-Lagrange formulation of system dynamics [8] and a real-time physics based simulator tool kit developed in the DTRL called the NASA Tensegrity Robot Toolkit (NTRT). There was also an uninstrumented physical drop test conducted, showing that a tensegrity robot could be built to withstand an impact force relative to that of Titan's terminal velocity. Though the simulator and initial drop test showed promising results, more extensive physical system validation is essential to prove that the system will function as expected.

2.2 Current SUPERball Prototype Build

As mentioned in section 1, SUPERball is a tensegrity robot in development in the DTRL. This prototype robot is a six bar tensegrity structure which forms an icosahedral geometric shape when all 24 cable lengths are equal. Every endcap is equipped with a micro-controller which monitors tensile forces in actuated and non-actuated endcap cables, 9-DOF IMU, wireless communication (2.4GHz and 900MHz), CAN 2.0B bus communication, battery/power monitoring, and 25 general

purpose expansion pins for extra peripherals. For the current iteration, each rod endcap is an active endcap capable of actuating one unique cable, thus 12 of the 24 cables within the main tensegrity structure are actuated. Although this scheme should enable us to achieve basic dynamic mobility, a 24 actuated structure will expand the manipulation and mobility space of the robot to maneuver across a multitude of terrain profiles, as well as comply to the state of the art in tensegrity robotic control schemes.

3 Drop Test Simulation Validation

In our previous work, we validated that a tensegrity structure would be able to survive an EDL scenario on Titan [5]. This validation was based on a simulated tensegrity structure with relatively realistic material prosperity specifications. In this work, we continue with physical drop testing and model refinement. This work is being conducted in collaboration with the University of Idaho.

3.1 Experimental Setup

For this drop test validation, a static tensegrity structure is used with various force and acceleration sensors as seen in figure 3. A test rig is used where the structure is suspended a known distance from a flat hard concrete surface such that two parallel rods impact the surface exactly orthogonal to the surface. This is a worst case landing scenario as stated in [5].

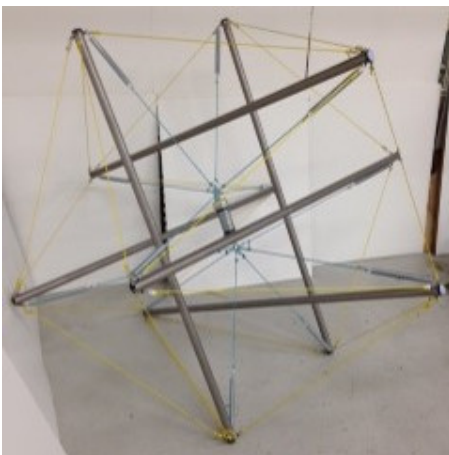

Figure 3. 1 meter tensegrity structure with linear springs for drop test validation. The structure is equipped with an acceleration sensor to monitor the payload and force sensors to monitor the cable forces.

Initially, the structure used parachute shock cord for the spring like elements in the structure, though the non-linear nature of the cord made the impact simulations in-

consistent with the simulation results due the simulator's model of linear springs. A non-linear spring model was implemented within the simulation environment, but the team was unable to fully determine the system identification for the non-linear model's coefficients. Consequently, the current structure utilizes external extension springs in line with relatively high stiffness cord, to model a known spring constant. This improved the simulation's linear spring results to match to the drop test experimental results.

3.2 Current Results

Initial data from the drop test structure, in comparison to the simulation model results, are promising for simulation validation. Figure 4 shows three repeated drop tests from the same height matching the simulated result's pattern. There are noise inconsistencies with the results, though this is most likely due to small mis-modeling in system identification parameters and unforeseen variations due to external environmental interference.

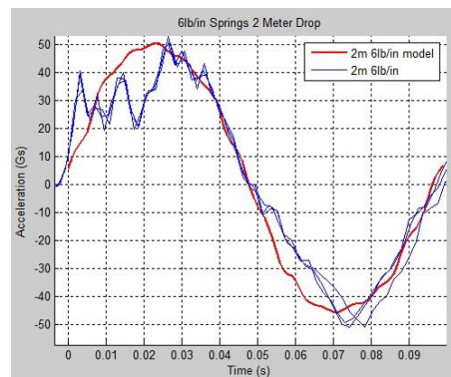

Figure 4. Accelerometer data from three identical drop tests overlaid with the simulated drop test in red.

4 Design for Full Mobility

Though a partially-actuated structure is adequate for basic mobility in the first generations of SUPERball, it is expected that more efficient and flexible control could be developed for future generations with a fully actuated system. Thus, this section explores work on creating a SUPERball with a fully actuated outer shell, one actuator for each of the 24 cables. This requires two actuators for each node of the structure, instead of the single motor. The same original set of engineering requirements were used for this redesign as for SUPERball [6], listed in Table 1, with the exception of the mass of each rod. Based on further simulations since the development of these criteria, it was determined that the initial weight requirement had

a much more variable relationship to system performance than was expected. And, since this design iteration is a proof-of-concept prototype, we did not want to limit our ability to find robust actuation schemes with this hard constraint. Thus, only two of these three criteria are categorized as hard constraints for our designs. The performance comparison table below contains other soft constraints of which weight is now one, relating to other important parameters of the designs.

Table 1. Original SUPERball Engineering Design Requirements. [6]

Parameter:	Value:
Mass Per Rod (kg)	1.5
Maximum Actuator Speed (cm/s)	60
Maximum Cable Force (N)	100

4.1 Concept Generation and Concept Evaluation

Working up from the current SUPERball design, five design concepts were developed and ranked according to these engineering specifications. The metrics are weight, movement, force, simplicity, manufacturability, and ability to obtain practical sensor measurements. Each of these design concepts use the same method of force generation, a brushless DC motor, but are different in their transmission mechanisms and modes of use. Each contained two actuators per endcap, instead of the single one currently on SUPERball.

4.1.1 Design Concepts

The aligned pulley block concept in Figure 5 has two motors attached to power screws that adjust cable lengths over pulley blocks, each with a fixed pulley interacting with a moving unit.

Since there is very limited space on a rod-like robot, and the stroke of the power screw is relatively short, these pulleys are used to magnify movement from the power screw nut. This design involves a long section of moving cable for the bottom (or inverted) motor, which leads to disadvantages in routing and supporting those cables under tension.

The parallel pulley block concept in Figure 6 uses a similar method of actuation as the aligned pulleys, but a different orientation. The pulley block units are now parallel to each other in a relative space-efficient orientation that does not require extensive routing of either set of high-tension cables.

The aligned winch concept in Figure 7 is a variation of the simple winch on the current SUPERball. It has the

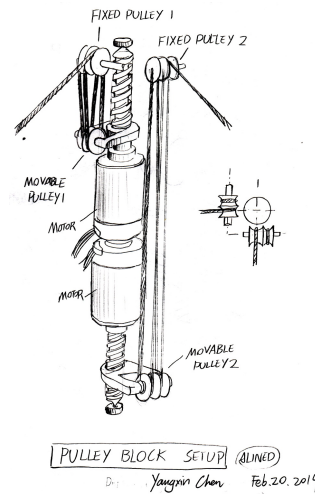

Figure 5. Design Concept 1: Aligned Pulley Block

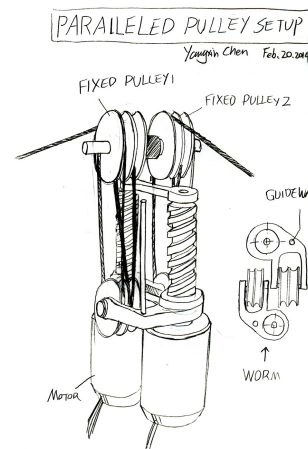

Figure 6. Design Concept 2: Parallel Pulley Block

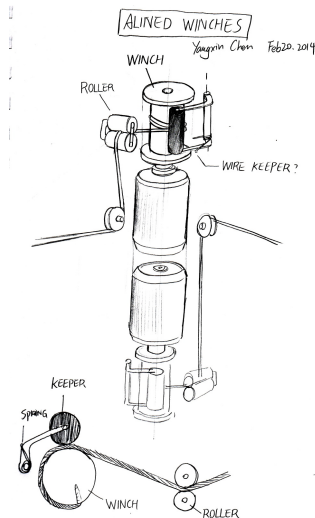

Figure 7. Design Concept 3: Aligned Winch

same disadvantages as the current design, such as difficulty of wrapping the cable reliably around the spindle, but also the cable routing difficulties in the aligned pulley concept.

Note that like the pulley blocks in figures 5 and 6, parallel winches were initially considered as an additional design concept, but was disregarded after a qualitative analysis of the space requirements of that orientation.

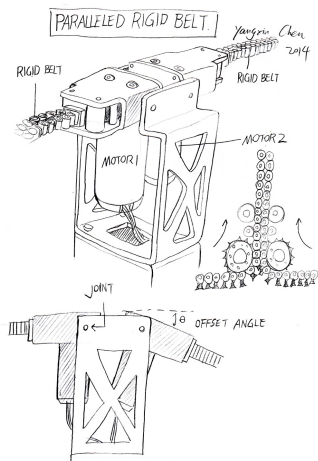

Figure 8. Design Concept 4: Rigid Belt

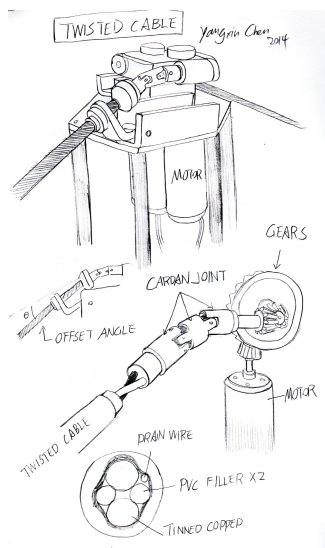

Figure 9. Design Concept 5: Twisted Cable

The rigid belt concept in Figure 8, also known as a zipper belt, is a specialized mechanical linear actuator that uses two reinforced plastic ribbed belts for force transmission. This technology is patented [9] [10], and the actuator can be purchased off-the-shelf. However, the belt is a performance hindrance: its rigidity causes issues for the required compliance of tensegrity systems. Another dis-

advantage is that there is no room to store the unzipped belts on the current robot design.

The twisted cable concept in Figure 9 is a version of a novel actuation technology that is under rapid development for robotic systems. Prior work has found twisted cable systems to be a simple but effective method of applying tension and displacement in robotic applications; the two most needed controls in a tensegrity robot [11] [12] [13] [14]. However, it is hindered by the unconstrained environment under which it will be used in the SUPERball design, which cannot prevent unwanted transverse deformations. Additionally, current technology does not have shortening and lengthening percentages and speeds which would meet current design requirements for SUPERball. Due to its excellent performance in other areas, though, it will likely be an excellent choice for tensegrity robotics in the future if these two main tradeoffs are resolved.

4.1.2 Concept Comparison and Selection

Table 2 shows a performance comparison matrix that compares these designs' features with those of the current 12-actuated SUPERball as the reference. Each comparison (positive, negative, or zero) arose from discussions and a qualitative analysis of each design's features. A negative/positive rating indicates that the proposed design is less/more favorable than the SUPERball reference. A zero indicates no difference.

The "parallel pulleys" design was qualitatively seen to be most promising. Consequently, it was chosen for further analysis. Future work on detail design, construction, and testing will be needed to make a final design decision.

4.2 Final Design Details

A version of the parallel pulleys design, having researched more details and designed sub-modules, is shown in the left figure in Figure 10. As was intuited during the comparison and selection process, this design retains simplicity of outer structure with easily-constructed components. Pulleys, bearings, leadscrews, slides, and rods are all sourced as off-the-shelf components. The right image in Figure 10 shows the actuation mechanism itself without any supporting structure.

Simple calculations were performed to confirm that this design would meet the engineering requirements. The power screws, part number SFK00801 from Deawoo Bearing Co., have a diameter of 8mm and pitch of $p = 5\text{mm}$. They are paired with a set of same 100W Maxon 386674 brushless DC motors as are in the current SUPERball. The initial concept has a series of $n_c = 4$ cables per pulley assembly. It was calculated using standard power screw analysis techniques [15] that the force on the cable would be 98.5N at a motor speed of 3000rpm and a cable output speed of 1m/s . This is within the Maxon motor's speed-torque curve for 100W operation. These

Table 2. Performance Comparison of Design Concepts.

Design Name:	Aligned Pulleys	Parallel Pulleys	Aligned Winch	Rigid Belt	Twisted Cable	Current SUPERball as Reference
Weight:	-	-	-	-	0	0
Movement Range:	0	0	+	0	-	0
Output Force:	+	+	0	+	0	0
Simplicity:	-	0	-	-	+	0
Manufacturability:	0	0	0	-	0	0
Ease of Sensing:	+	+	0	+	-	0
Net Performance:	0	+	-	-	-	0

two metrics, $98N$ and $1m/s$, satisfy the hard constraints in table 1.

In comparison to the current partially-actuated design of SUPERball, this design does have certain disadvantages.

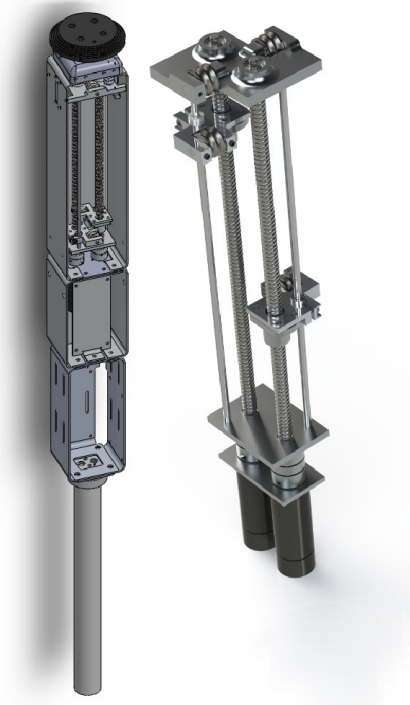

Figure 10. Left: Rendering of detail design for parallel pulleys concept found in figure 6. Right: Core of redesign without housing.

This was to be expected: this redesign adds an enormous amount of functionality, that was expected to increase cost and complexity while sacrificing weight and potentially speed. However, although this may not have been captured in our performance comparison, full actuation is seen as critical enough to our mission’s success that

it will allow for these affordances.

The same principles of design for manufacturing and assembly were applied to parallel pulleys as were applied to the current SUPERball. Both designs are certain to be prototyped in research phases, which limited the availability of expensive materials. Consequently, certain aspects of the current SUPERball were carried over into the parallel pulleys redesign, such as the endcap shaft collar and sheet metal housing design. However, more analysis must be performed in future work to confirm the structural integrity of these carry-over designs for the new actuation configuration.

Some details in the SUPERball design were neglected when developing this concept of parallel pulleys. For example, the passive cable-spring system [6] [16] was not included here. Consequently, there are anticipated challenges with fully integrating this new redesign into the current system. Components such as the attachment shaft collar will need to be re-sized for a larger rod, as will all the structural parts, for practical use. These details will be more informed once data is collected on the end actuator weight, as tests are performed on the current SUPERball.

5 Conclusions and Future Work

Two important steps have been taken in this work toward realization of a tensegrity-based planetary exploration mission. First, prior simulation results of forces on a payload in a 6-bar tensegrity icosahedron were validated against a physical model. This data and subsequent analysis allows for continued development of more sophisticated engineering requirements. Additionally, the current set of engineering requirements were applied in the process of developing and evaluating concepts for a fully-actuated redesign of the current 6-bar icosahedron SUPERball. A promising design was developed that met the most important requirements.

However, both the development and use of these engineering requirements require future work. Though the structural forces on a center payload have been tested, a

model is required that relates these forces to those within the outer structural members. Work continues on applying a physics-based analytical model that would be appropriate for interpreting the variety of other sensor data that was recorded in these drop tests. Certain other drop test experiments may be necessary, including those with the SUPERball itself once a full structure has been assembled.

For the 24 actuator redesign, continued work is needed on more in-depth detail design, analytical structural calculations, and testing. Any outstanding conflicts with the current SUPERball design must be resolved, and a more thorough design for assembly must be performed once these details have been specified.

6 Acknowledgments

This research was supported by the NASA Innovative Advanced Concepts program. Support also came from NSF Graduate Research Fellowship No. DGE1106400, and by NASA Prime Contract Number NAS2-03144 awarded to the University of California, Santa Cruz, University Affiliated Research Center.

The authors are extremely grateful for the work of teams at both UC Berkeley and University of Idaho which assisted in the two sub-projects within this work, as well as fellow members of the Dynamic Tensegrity Robotics Lab at NASA Ames. Specifically, we would like to thank Kyunam Kim, Yuejia Liu, Brian Tietz, Ryan Adams, Adrian Agogino, In Won Park, Atil Iscen, Alex Ackerman, Nick Clyde, Will Hoffman, Mary Yovanoff, Brenden Kaschmitter, and Matthew Riley.

References

- [1] G. Tibert, "Deployable tensegrity structures for space applications," Ph.D. dissertation, Royal Institute of Technology, 2002.
- [2] A. Agogino, V. SunSpiral, and D. Atkinson, "Super Ball Bot - structures for planetary landing and exploration," *NASA Innovative Advanced Concepts (NIAC) Program, Final Report*, 2013.
- [3] N. Wang, J. D. Tytell, and D. E. Ingber, "Mechanotransduction at a distance: Mechanically coupling the extracellular matrix with the nucleus." *Nature Reviews Molecular Cell Biology*, vol. 10, no. 1, pp. 75–82, 2009.
- [4] S. Levin, "The tensegrity-truss as a model for spine mechanics: Biotensegrity," *Journal of Mechanics in Medicine and Biology*, vol. 2, pp. 375–388, 2002.
- [5] V. SunSpiral, G. Gorospe, J. Bruce, A. Iscen, G. Korbel, S. Milam, A. Agogino, and D. Atkinson, "Tensegrity based probes for planetary exploration: Entry, descent and landing (EDL) and surface mobility analysis." *International Journal of Planetary Probes*, July 2013.
- [6] J. Bruce, K. Caluwaerts, A. Iscen, A. P. Sabelhaus, and V. SunSpiral, "Design and evolution of a modular tensegrity robot platform," in *IEEE International Conference on Robotics and Automation (ICRA-2014)*, 2014.
- [7] A. Iscen, A. Agogino, V. SunSpiral, and K. Tumer, "Controlling tensegrity robots through evolution," in *GECCO*, 2013.
- [8] C. Sultan, M. Corless, and R. E. Skelton, "Linear dynamics of tensegrity structures," *Engineering Structures*, vol. 24, no. 6, pp. 671–685, 2002.
- [9] H. Yaichi, "Interlocking chain stanchion," May 22 1951, uS Patent 2,554,300. [Online]. Available: <http://www.google.com/patents/US2554300>
- [10] J. Bourc'His, "Linear belt actuator," Nov. 4 2004, uS Patent App. 10/481,870. [Online]. Available: <https://www.google.com/patents/US20040220004>
- [11] C. Kossowski and L. Notash, "Cat4 (cable actuated truss4 degrees of freedom): A novel 4 dof cable actuated parallel manipulator," *Journal of Robotic Systems*, vol. 19, no. 12, pp. 605–615, 2002.
- [12] R. L. Williams II and P. Gallina, "Translational planar cable-direct-driven robots," *Journal of Intelligent and Robotic systems*, vol. 37, no. 1, pp. 69–96, 2003.
- [13] S. Kawamura, W. Choe, S. Tanaka, and S. R. Pandian, "Development of an ultrahigh speed robot falcon using wire drive system," in *Robotics and Automation, 1995. Proceedings., 1995 IEEE International Conference on*, vol. 1. IEEE, 1995, pp. 215–220.
- [14] K. Maeda, S. Tadokoro, T. Takamori, M. Hiller, and R. Verhoeven, "On design of a redundant wire-driven parallel robot warp manipulator," in *Robotics and Automation, 1999. Proceedings. 1999 IEEE International Conference on*, vol. 2. IEEE, 1999, pp. 895–900.
- [15] R. G. Budynas and J. K. Nisbett, "Shigleys mechanical engineering design," 2008.
- [16] A. P. Sabelhaus, K. Caluwaerts, J. Bruce, Y. Chen, D. Lu, Y. Liu, A. M. Agogino, and V. SunSpiral, "Hardware Design and Testing for SUPERball, a Mobile Tensegrity Robot," in *6th World Conference on Structural Control and Monitoring*, 2014, to appear.